

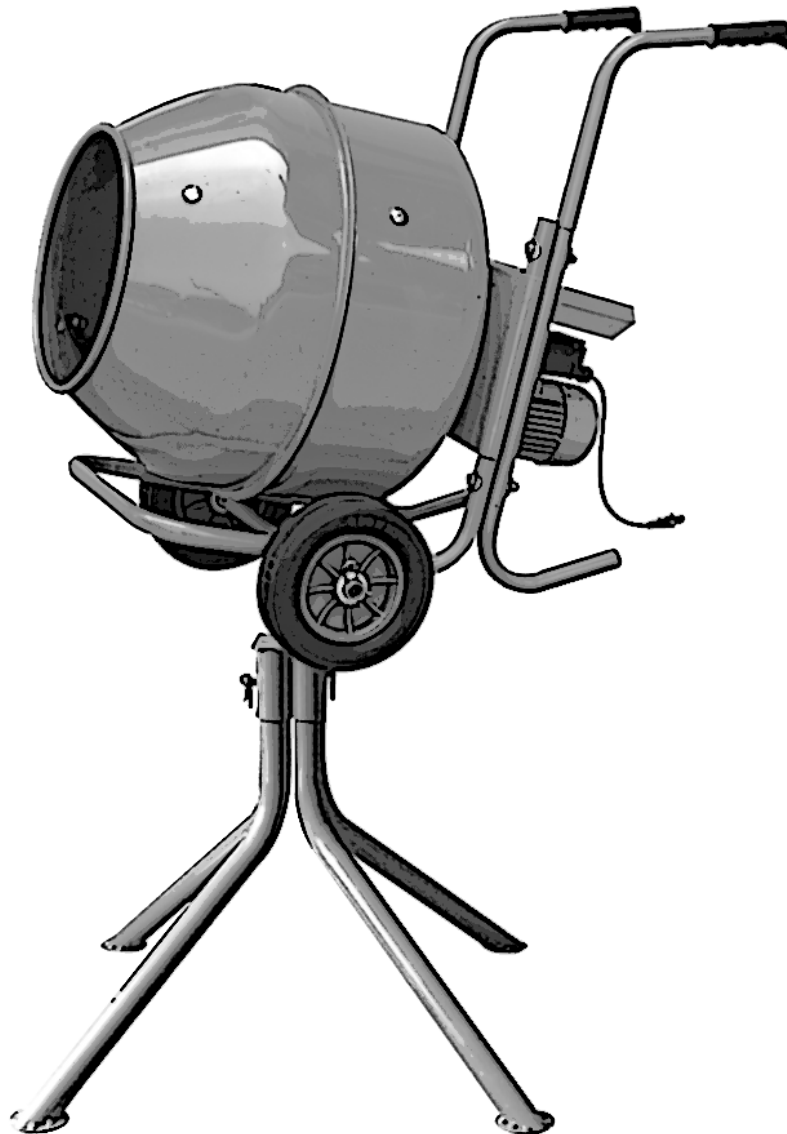

VERTICAL & HORIZONTAL CEMENT MIXER

XH-PCMS-H-SD INSTRUCTION MANUAL







IMPORTANT:

Please carefully read this manual before using this device and save this manual for future reference.

IMPORTANT SAFETY INSTRUCTIONS

SAFETY GUIDELINES DEFINITIONS

| | |
|---|--|
|  | DANGER: Indicates an imminently hazardous situation which, if not avoided, will result in death or serious injury. |
|  | WARNING: Indicates a potentially hazardous situation which, if not avoided, could result in death or serious injury. |
|  | CAUTION: Indicates a potentially hazardous situation which, if not avoided, could result in minor or moderate injury. |
|  | NOTE: Indicates a practice not related to personal injury which, if not avoided, may result in property damage. |

IMPORTANT SAFETY INSTRUCTIONS

This product is not intended for use by persons suffering from diminished physical, sensory or mental abilities; lack of experience, knowledge or skills unless they are supervised by a person responsible for their safety. Keep children away.

WARNING: FOR YOUR OWN SAFETY READ INSTRUCTIONS MANUAL BEFORE OPERATING THIS CEMENT MIXER. WEAR EYE PROTECTION

AVERTISSEMENT: POUR VOTRE PROPRE SÉCURITÉ, LIRE LE MANUEL D'UTILISATION AVANT D'UTILISER CE MÉLANGEUR DE CIMENT. PROTECTION DES YEUX

OBSERVE WORK AREA CONDITIONS

DANGER:

- Do not operate cement mixer in explosive atmospheres, such as in the presence of flammable liquids, gases or dust. Electric motors create sparks which may ignite the dust or fumes.
- Do not use in wet conditions.

OBSERVE WORK AREA CONDITIONS (CONTINUED)

WARNING:

- **Keep children and bystanders away while operating the cement mixer.**
- **Work area should be clear of debris and obstructions.**
- **Ensure all tools and other equipment are removed from area and the cement mixer drum before operating.**
- **The cement mixer should be on a level surface to prevent tipping, rolling or falling.**

ELECTRICAL SAFETY

DANGER:

- **When operating the cement mixer outdoors or in a damp environment, use a ground fault circuit interrupter (GFCI) protected power supply.**
- **USE ONLY ON GROUNDED 3 PRONG 120V, 60Hz OUTLETS**
- **USE ONLY 3 WIRE 14AWG MINIMUM WITH 3 BLADE GROUNDING PLUG AND A 3 SLOT RECEPTACLE.**
- **UNDERSIZED CORDS WILL CAUSE VOLTAGE DROP RESULTING IN LOSS OF POWER AND OVERHEATING**
- **Avoid body contact with earthed or grounded surface such as pipes, radiators, ranges and refrigerators. This is an increased risk of electric shock if your body is earthed or grounded.**
- **DO NOT EXPOSE CEMENT MIXER TO RAIN OR WET CONDITIONS.** Water entering an electric motor will increase the risk of electric shock.

WARNING:

- **Do not abuse the cord. Keep cord away from heat, oil, sharp objects and moving parts. Never use the cord for carrying, pulling, or unplugging the unit.**
- **Never modify the plug in anyway.**
- **If the power cord is damaged, it must be replaced by the manufacturer, service agents or similarly qualified person in order to avoid a hazard.**

PERSONAL SAFETY

DANGER:

- **Do not wear loose clothing or jewelry. Keep your hair, clothing and gloves away from moving parts.** Loose clothes, jewelry or long hair can be caught in moving parts.
- **Do not place hands or tools (ie. shovel) in or around the drum while operating.** Personal injury could occur.
- **DO NOT place hands in or around the drum while operating.**

WARNING:

- **Use personal protective equipment. Always wear eye protection.** Protective equipment such as a dust mask, non-skid safety shoes, hard hat or hearing protection used for appropriate conditions will reduce the risk of personal injuries.

CEMENT MIXER USE AND CARE

WARNING:

- Disconnect the plug from the power source before servicing, adjusting, installing accessories or attachments.
- Never leave cement mixer running unattended. Always unplug when not in use.
- Do not allow persons unfamiliar with the cement mixer or these instructions to operate the cement mixer.
- Contact electrician if grounding instructions are not understood.

CAUTION:

- Ensure drum is empty before transporting.
- Do not overload mixer. See Specifications, page 2 for load capacity. Overloading could cause damage to the cement mixer.
- Store cement mixer out of the reach of children.
- Maintain the cement mixer. Check for wear and damaged parts. Before each use ensure the cement mixer operates properly. Any broken or missing parts must be repaired or replaced before using. Many accidents are caused by poorly maintained cement mixer.

NOTE:

- Keep the cement mixer clean. Clean after each use.
- Ensure drum is rotating when filling or emptying the mixer. This ensures a good mix and prevents damage to the motor.
- Be familiar with concrete mix being used, particularly quick set formulas. This is important when motor overload protection shuts off the motor to prevent motor damage.
- Only use accessories recommended by the manufacturer.
- Always practice environment pollution procedures. Clean out the drum in a designated area where the concrete and rinse water can be contained. Concrete and rinse water can pollute storm drains and surface water.
- Use the cement mixer in accordance with these instructions, taking into account the working conditions and the work to be performed. Use of the cement mixer for operations different from those intended could result in a hazardous situation.

SERVICE

WARNING:

- **Have the cement mixer serviced by a qualified repair person using identical replacement parts.** This ensures the cement mixer is properly maintained.

SPECIFICATIONS

| | |
|--------------------------------|---|
| Drum Capacity | 5 Cubic Feet |
| Batch Capacity | 2.5 Cubic Feet - 270lbs (122 kg) |
| Drum Diameter | 24" (61 cm) |
| Discharge Outlet Height | 41" (104 cm) |
| Wheels | 12" x 2-1/2" (30.5 x 6.5 cm) |
| Weight | 143lbs (65 kg) |
| Electric Motor | 120V / 60Hz @ 6.3A |
| Motor HP | 0.5 |
| Motor Speed/Drum Speed | 1440RPM/26-28RPM |
| Protection Rate | IP 55 |
| Measured Sound Level | 89.96 dB(A) |
| Gauranteed Sound Level | 92.0 dB(A) |

PARTS DIAGRAM

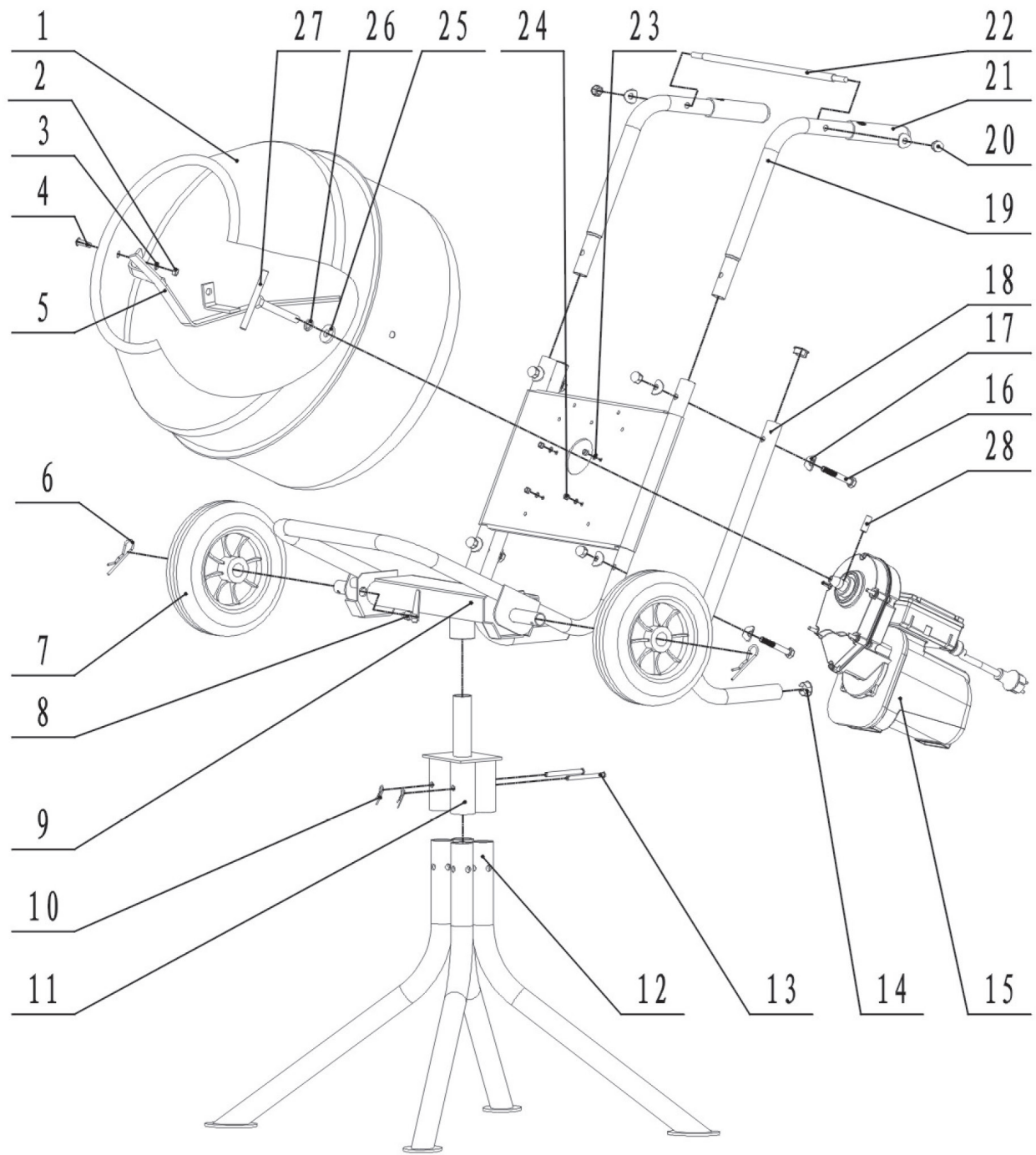

PARTS LISTS

| Item# | Description | QTY | Item# | Description | QTY |
|-------|--------------------|-----|-------|--------------------|-----|
| 1 | Mixing Drum | 1 | 15 | Motor and Gear Box | 1 |
| 2 | Nut M12 | 4 | 16 | Bolt (M10 x 75 mm) | 4 |
| 3 | Washer Ø12 | 4 | 17 | Washer Ø8 | 8 |
| 4 | Screw (M12 x 21mm) | 4 | 18 | Rear Stand | 2 |
| 5 | Mixing Paddle | 2 | 19 | Handle | 2 |
| 6 | Large Cotter Pin | 2 | 20 | Cover Nut | 6 |
| 7 | 10" Wheel | 2 | 21 | Handle Bar | 2 |
| 8 | Securing Clip Lock | 1 | 22 | Reinforced Pole | 1 |
| 9 | Frame | 1 | 23 | Washer Ø6 | 4 |
| 10 | Small Cotter Pin | 2 | 24 | Nut Ø6 | 4 |
| 11 | Stand Connector | 1 | 25 | T-Bolt Washer | 1 |
| 12 | Stand (4 leg set) | 1 | 26 | Spring Washer | 1 |
| 13 | Axle Pin | 2 | 27 | T-Bolt | 1 |
| 14 | Plastic Plug | 4 | 28 | Positioning Pin | 1 |

ASSEMBLY

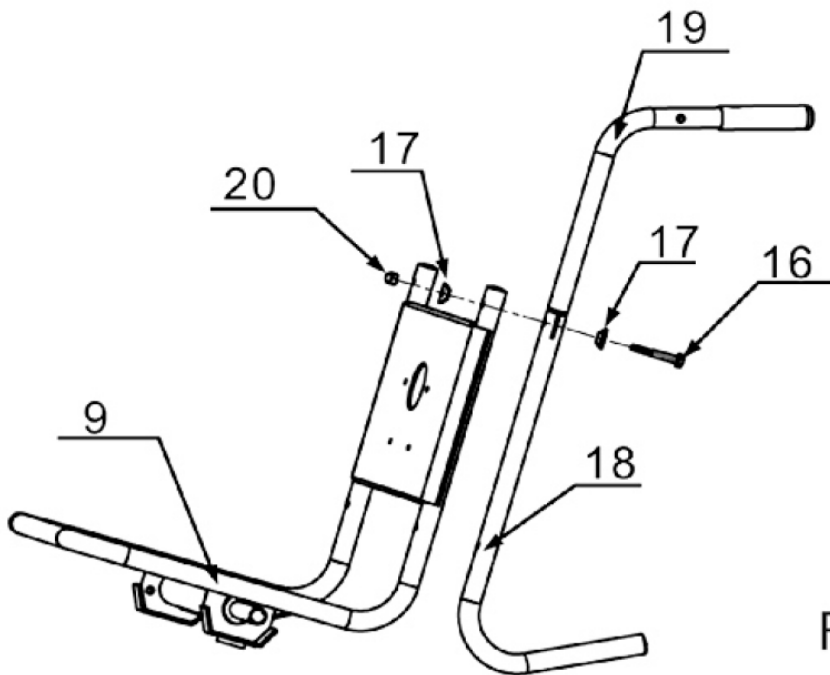

1. Insert left handle (19) into rear stand (18), align fixing hole with chassis (9) using screws (16), washers (17), nuts (20). Repeat for right hand side. (Fig. 1)

DO NOT COMPLETELY
TIGHTEN ALL FASTENERS
YET

Fig. 1

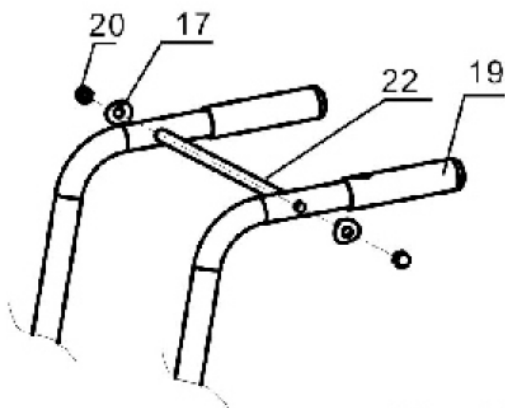

Fig. 2a

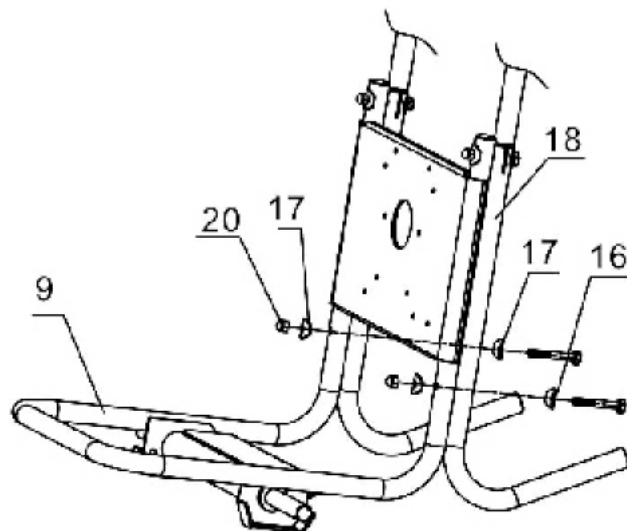

Fig. 2b

2. Assemble reinforced pole (22) between two handles (19) using washer (17), nuts (20). (Fig. 2a)

Secure handle (19) & rear stand (18) with frame (9), using screws (16) washers (17), nuts (20). (Fig. 2b)

NOW TIGHTEN ALL FASTENERS FROM STEP 1 & 2

ASSEMBLY

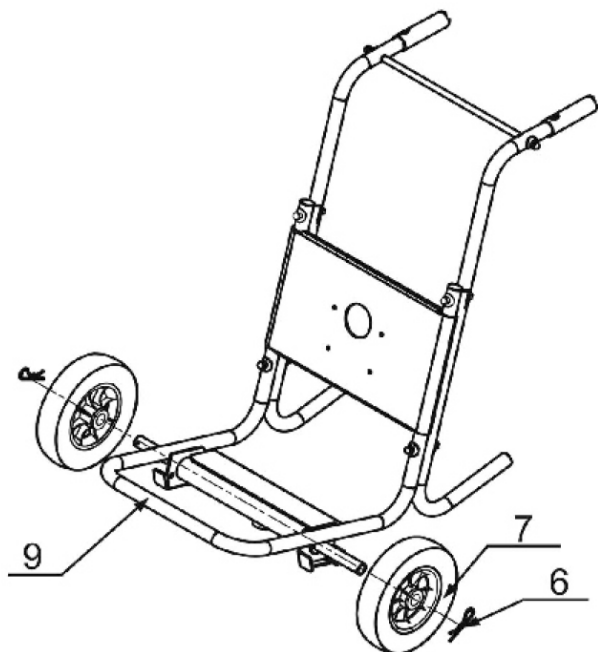

3. Slide the wheels (7) onto the axles of the frame (9), secure the wheels with the big cotter pins (6). (Fig. 3)

Fig. 3

4. Attach the motor and gearbox assembly (15) via the four studs through the frame (9) using washers (23) and nuts (24). (Fig. 4)

TIGHTEN ALL FASTENERS

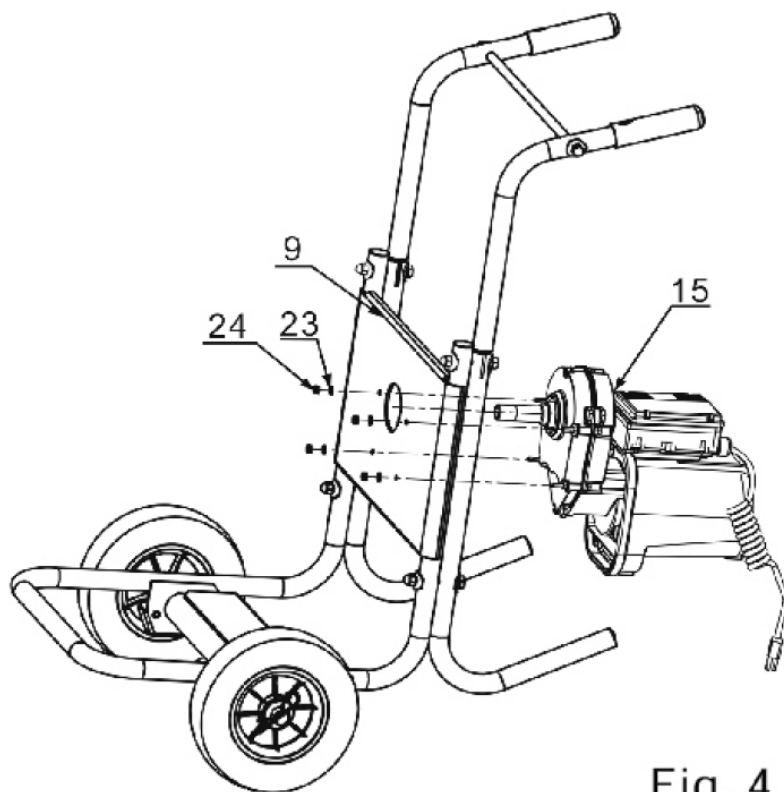

Fig. 4

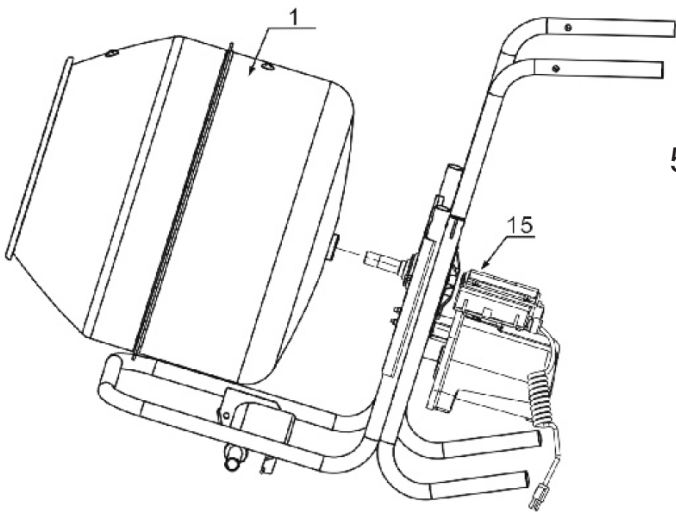
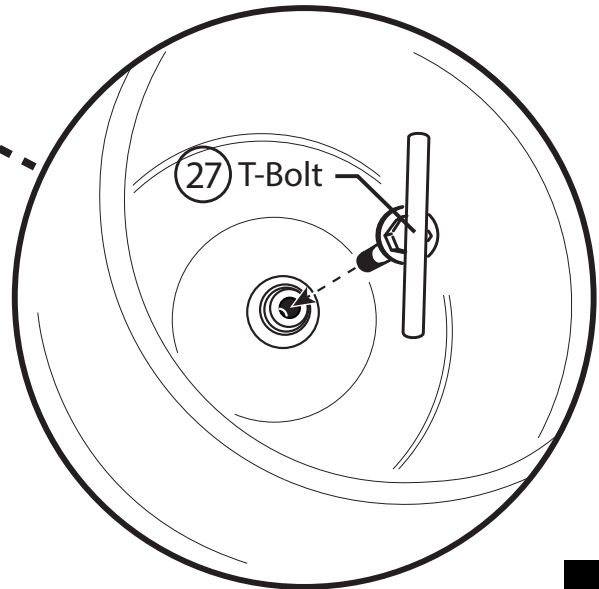
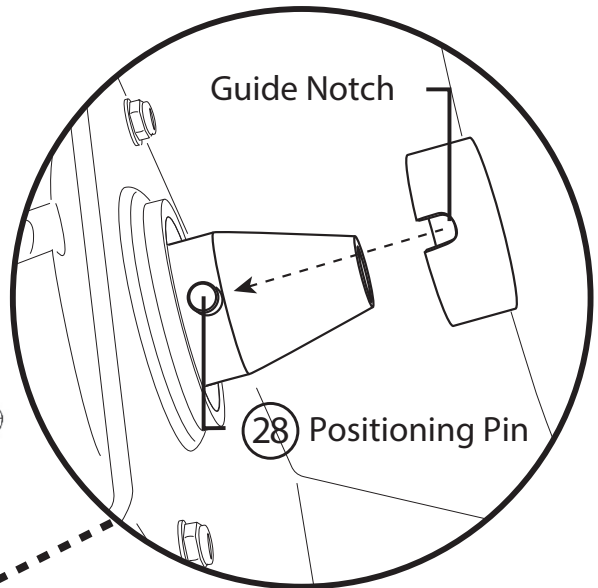
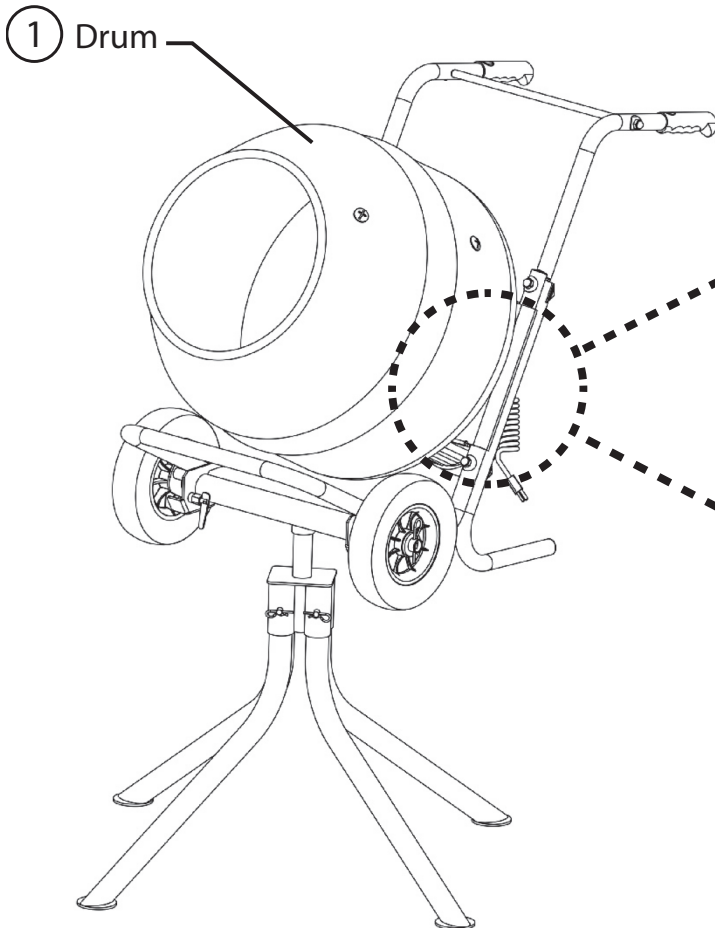

Fig. 5

5. To mount the Drum (1), align the Guide Notch at the bottom of the mixing Drum (1) to the Positioning Pin (28) on the gear box shaft. (Fig. 5 & Fig. 6)

Fig. 6



- Slide T-Bolt Washer (25) and Spring Washer (26) onto the T-Bolt (27). Then Tightly secure the Drum (1) using the T-Bolt (27). Turn drum in clockwise direction. Secure T-Bolt as tight as possible. (Fig. 7)

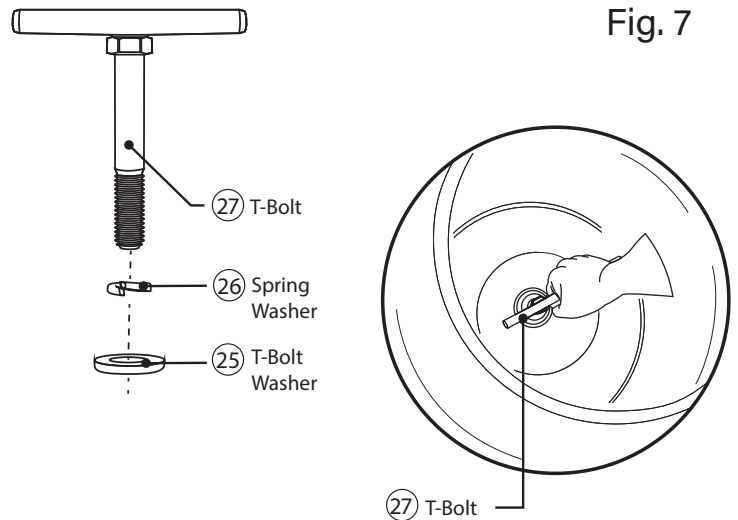

IMPORTANT:
MAKE SURE THAT THE DRUM DOES NOT WIGGLE OUT OF PLACE FROM THE GEAR BOX SHAFT. T-BOLT MUST BE SECURELY TIGHTEN. ENSURE THERE IS NO PLAY BETWEEN THE DRUM AND GEAR BOX SHAFT

Fig. 8

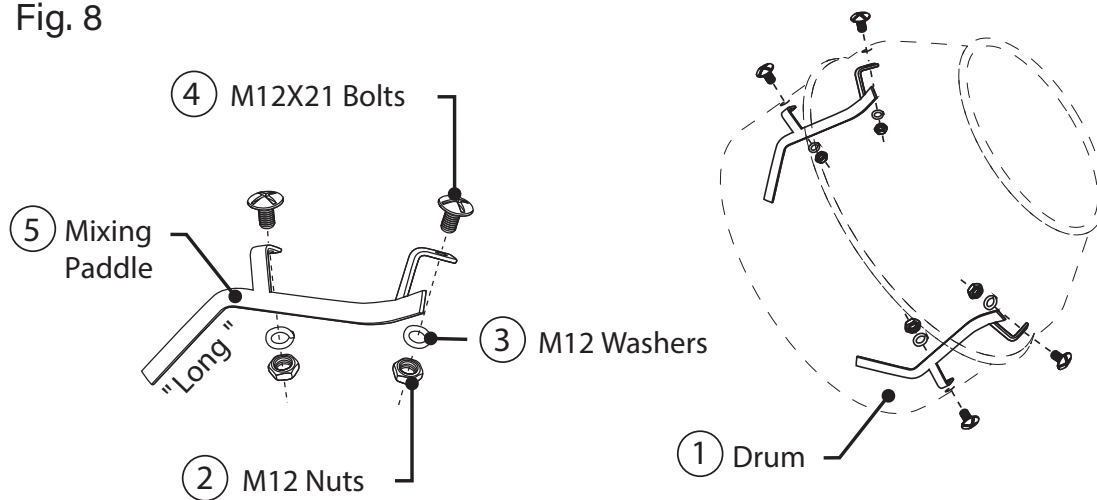

- Secure the mixing paddle (5) to the inner drum (1) with nuts (2), washers (3), and screws (4). (Fig. 8)
- Assemble the stand (12) and fit into the bottom inlet of the frame (9).

IMPORTANT
MAKE SURE THE AXLE PINS (13) IS ENGAGED BY THE SMALL COTTER PINS (10) BEFORE LIFTING OR LOWERING THE MIXER. (Fig. 9)

Fig. 9

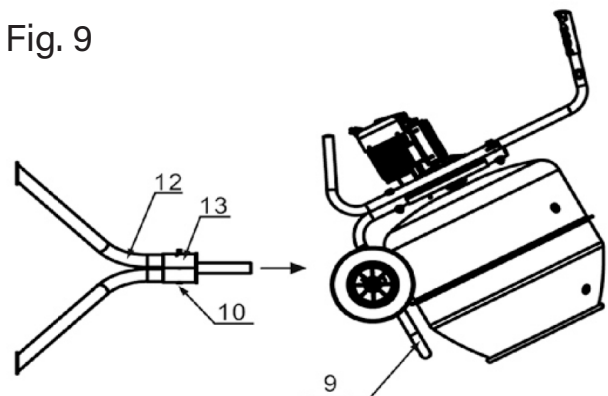

OPERATIONS

BEFORE USE

- Before each use, inspect that the cotter pins are in place and that all nuts, bolts and screws are fully tight.
- Inspect the product before each use for worn and damaged parts. Do not operate if you find broken and worn parts. Contact your authorized service center for repair before using the product again.
- Ensure that the securing clip lock on the swivel bracket is in the locked position before placing the cement mixer on the cement mixer stand.

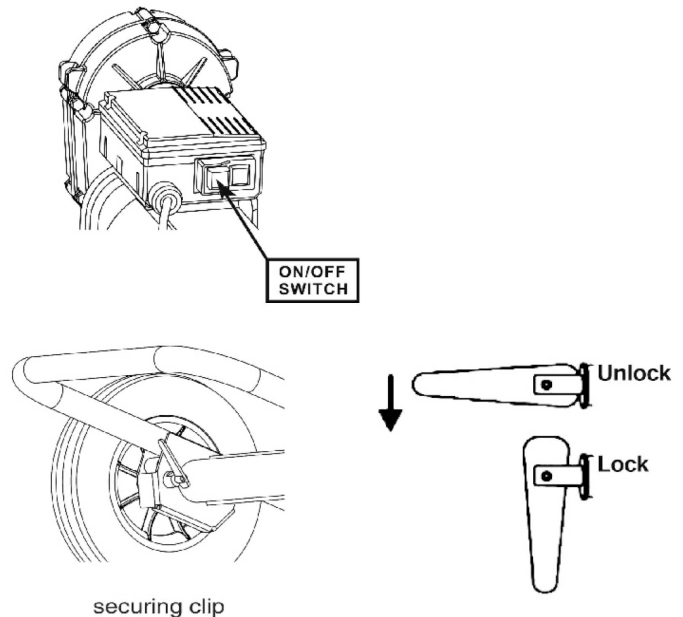

MIXING

1. Position the mixer on a level surface. 5° is the maximum slope the cement mixer may be placed on. **DO NOT OPERATE CEMENT MIXER ON SLOPES.**

LOADING THE DRUM



ENSURE THE T-BOLT IS TIGHT BEFORE USE.

1. Lift the cover for the cement mixer motor. Press the Start button. Run the cement mixer on for 3 to 5 minutes before loading the cement mixer for the first time.
2. When the drum is rotating, add water, one shovel full of aggregate (gravel) and cement. The aggregate will break up the lumps in the cement. Add remaining aggregate (gravel) and sand according to the concrete manufacturer's instructions.
3. Water, cement, aggregate (gravel) and sand ratios vary depending on job specifications. Always read the concrete manufacturer's instructions.

UNLOADING CEMENT

- Flip the Locking Pin up, to enable the drum to tilt on Cement mixer stand. With the drum rotating, hold both handles and place one foot on rear stand and tilt the drum to pour concrete.
- When tilting the drum to pour the concrete, do so slowly to keep the cement mixer balanced and upright.

MAINTENANCE



NOTE: OVERLOAD POWER PROTECTOR

- The motor has a thermal overload protector. If the motor overheats for any reason, the overload protector will shut off the motor. Unplug the cement mixer and allow the motor to cool down before restarting.
- To restart the cement mixer, turn the mixer on by pressing the start button.

CLEANING & STORAGE

1. Clean the product with a dry cloth. Use a brush for areas that are hard to reach. Clean all air vents after every use with a cloth and brush.
2. Between Batches clean out the drum. Turn on the mixer then dump a bucket of water in the drum and allow it to run until the drum is clean. While the drum is still rotating, hold the handles, place one foot on rear stand to prevent tipping and tilt drum to dump debris.
3. Right after use, clean out the drum with water. If cement has dried up in the inside of the mixer, tap the outside of the drum with a rubber or plastic mallet. Dump mixer to empty dried cement from drum. **(DO NOT USE A STEEL HAMMER TO DISLodge DRIED CEMENT FROM MIXER).**



WARNING:

- DO NOT SPRAY WATER IN OR AROUND THE MOTOR ASSEMBLY.
- Before performing inspection, maintenance and cleaning, always switch the unit off. Disconnect it from the power supply and let the product cool off.
- Only perform repairs and maintenance work according to these instructions. All further works must be performed by a qualified specialist.
- Always hold the cement mixer by its handles. Keep the handle dry to ensure safe support.
- Before opening the motor housing, disconnect the power supply. Only operate the cement mixer when the motor housing is fully closed.
- **DO NOT TURN THE CEMENT MIXER OFF WHEN IT IS FULL OF CEMENT. THIS WILL DAMAGE THE MOTOR AND GEAR BOX.**
- **DO NOT place hands in or around the drum while operating.**

TROUBLE SHOOTING

| ELECTRICAL | |
|---|---|
| PROBLEM | RESOLUTION |
| Motor does not run before loading concrete. | Check power connection. Connect if needed. |
| | Ensure the green ON (I) button is pressed. |
| | Do not use an extension cord that is below 14AWG 3-Prong. |
| | Motor overload protector tripped. Allow unit to cool then restart (Page. 12) |
| Motor does not run with concrete loaded. | Check power connection. Connect if needed. |
| | Ensure power connection voltage is 110V-120V |
| | Ensure the green ON (I) button is pressed. |
| | Motor overload protector tripped. Allow unit to cool then restart (Page. 12) |
| | Empty load, start mixer empty, refill mixer. |
| Mixer shuts down suddnely while mixing. | Check power connection. Connect if needed. |
| | Do not use an extension cord that is below 14AWG 3-Prong. |
| | Motor overload protector tripped. Allow unit to cool then restart (Page. 12) |

| MECHANICAL | |
|--|--|
| PROBLEM | RESOLUTION |
| Drum does not turn when motor is running. | Ensure alignment pin is properly placed in guide notch on drum. |
| | Ensure T-bolt inside drum is tight. (See Pages 9-10) |
| Irregular noise when drum is spinning. | Ensure T-bolt inside drum is tight. (See Pages 9-10) |
| | Remove drum and clean the gearbox drive shaft and drum with soft clean cloth. |
| The drum suddenly drops down during operation. | Ensure T-bolt is not broken. If T-bolt is broken: Remove drum and clean the gearbox drive shaft and drum with soft clean cloth. Install new T-bolt and reassemble drum. |

WARRANTY

1-Year Limited Warranty

This product is guaranteed for a period of one (1) year from the date of original retail purchase, against defects in materials and workmanship. Subject to the conditions and limitations described below, this product, if returned to us with proof of purchase within the stated warranty period and if covered under this warranty, will be repaired or replaced (with the same model, or one of equal value or specification), at our option. We will bear the cost of any repair or replacement and any costs of labour relating thereto.

These warranties are subject to the following conditions and limitations

- a) a bill of sale verifying the purchase and purchase date must be provided;
- b) this warranty will not apply to any product or part thereof which is worn or broken or which has become inoperative due to abuse, misuse, accidental damage, neglect or lack of proper installation, operation or maintenance (as outlined in the applicable owner's manual or operating instructions)
- c) this warranty will not apply to normal wear and tear or to expendable parts or accessories that may be supplied with the product which are expected to become inoperative or unusable after a reasonable period of use;
- d) this warranty will not apply to routine maintenance and consumable items such as, but not limited to, concrete mix, aggregate (gravel), lubricants, vacuum bags, blades, belts, sandpaper, bits, fluids, tune-ups or adjustments;
- e) this warranty will not apply where damage is caused by repairs made or attempted by others (i.e. persons not authorized by the manufacturer);
- f) this warranty will not apply to any product that was sold to the original purchaser as a reconditioned or refurbished product (unless otherwise specified in writing);
- g) this warranty will not apply to any product or part thereof if any part from another manufacturer is installed therein or any repairs or alterations have been made or attempted by unauthorized persons;
- h) this warranty will not apply to normal deterioration of the exterior finish, such as, but not limited to, scratches, dents, paint chips, or to any corrosion or discolouring by heat, abrasive and chemical cleaners; and
- i) this warranty will not apply to component parts sold by and identified as the product of another company, which shall be covered under the product manufacturer's warranty, if any.

RAM

I N T E R N A T I O N A L

RAM International Enterprise Ltd / Inter-Pacific Trading Corp.
#113 - 11280 TWIGG PLACE RICHMOND BC
CANADA V6V0A6
www.raminternational.ca